



# PRI-35



COLOR OPTIONS	
Red	
Royal Blue	
Hunter Green	
Black	
Canary Yellow	
Burgandy	

Warranty:  
2 year parts -  
Life time on workmanship

**PRI-35 pictured with cyclone Included**

## Technical Specifications

Batch Capacity	Green 45 lbs.	Roasted. 35 lbs.
Roasted Capacity per hour.	140 lbs.	
Crated Shipping Weight.	1650 lbs.	
Dimensions	69" High x 66" Deep x 29" Wide not including cyclone	
Electrical	110 V = 25.5 Amps	220 V = 14.5 Amps
CFMS	Roasting = 360	Cooling = 1125
Gas Supplied 3/4" inlet	Natural	Propane
Venting	Cooler = 6"	Cyclone = 6"

## Standard Features

- Two-staged digital temperature controller.
- Chaff Cyclone collector.
- Brushed Stainless Steel Face Plate
- Aluminum Trim.
- IR Burners

## Upgrades Available

- Fire Suppression in Cyclone
- Vacuum Loader
- Custom Paint

# PRI-35 Layout Sheet

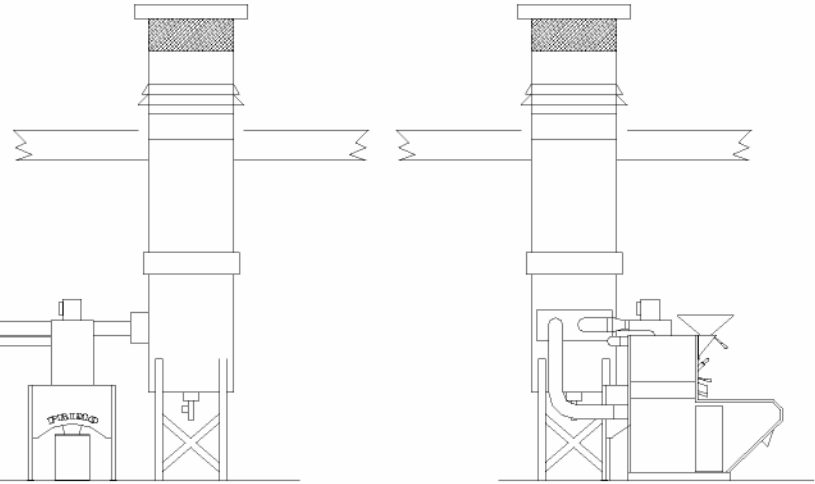
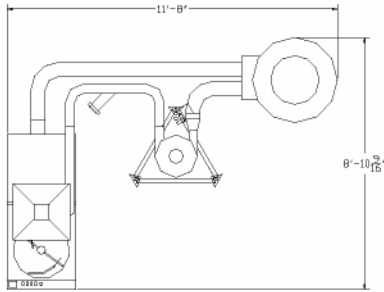

WITH AFTERBURNER

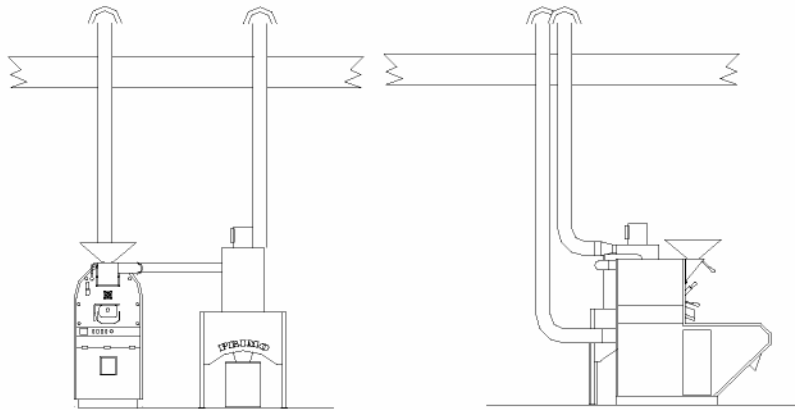
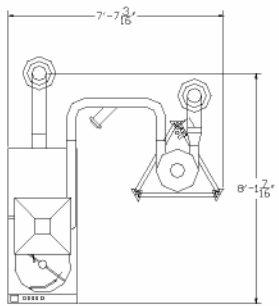
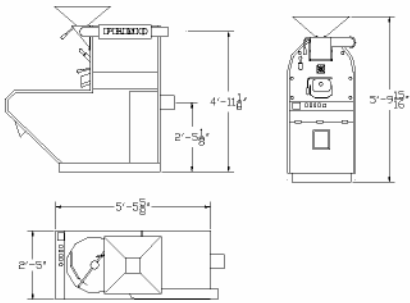

WITHOUT AFTERBURNER

PRI-20 LB-35 LB		
REV. 1	09/12/02	TOM OVERY
PRIMO ROASTING INC. 1717 NEWPORT CIRCLE SANTA ANA, CA 92705 1-714-556-5259		