

2024

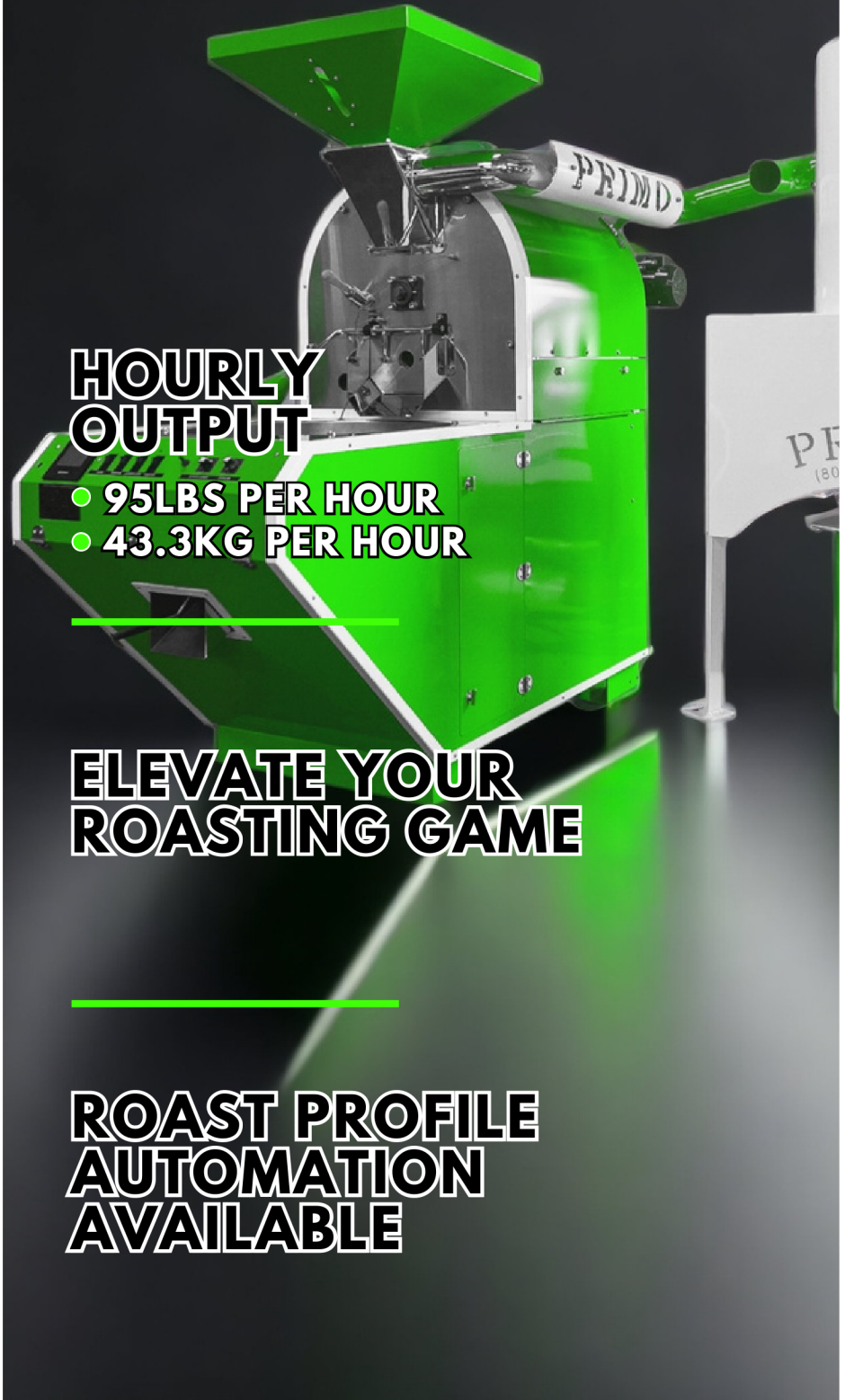

# RAVEN-XR15

**NO.15**



## HOURLY OUTPUT

- 95LBS PER HOUR
- 43.3KG PER HOUR

**ELEVATE YOUR ROASTING GAME**

**ROAST PROFILE AUTOMATION AVAILABLE**



# RAVEN-XR15

**95 LBS. PER HOUR**

Roast Time: 9 - 14 Minutes  
Two - Year Warranty



## CONTACT



**Phone**  
1.800.675.0160



**Email**  
info@primoroasting.com



**Address**  
1309 S. Lyon St. Santa Ana  
CA, 92705



## CAPACITY



**15 - 33 lbs. Batch Sizes.**



**43.3 Kg Per Hour.**



## TECHNOLOGY

- Infrared Burner
- Roast Profile Software
- Two-Year Warranty
- Adjustable Airflow
- Adjustable Drum Speed
- Independent Cyclone for Max Chaff Collection



## ROASTER INFO

Introducing our the Raven-Xr15. The Raven has the production capacity to keep up with your expanding business.



## SPECIFICATIONS



### Infrared Burner for Efficiency and a More Consistent Roast

Equipped with state-of-the-art temperature sensors and a powerful infrared heating system, the Raven-Xr15 ensures consistent heat distribution throughout the roasting process. Whether you prefer a light, medium, or dark roast, this roaster empowers you to achieve your desired roast profile with ease.



### Carbon Steel Construction

Built with durability and precision in mind, the Raven-Xr15 features high-quality carbon steel construction and a robust drum design that ensures optimal heat transfer and even roasting.



### Roast and Cool Simultaneously

The integrated cooling system allows for simultaneous roasting and cooling. Increase production, productivity, and consistency with our built-in system.



## ADDITIONAL OPTIONS

Adjustable Airflow

Adjustable Drum Speed

USB - Profile Software

Manual Gas Override

Propane or Natural Gas

Double Walled Drum



## SALES INFORMATION

### Christian

Primo Roasting / CMO  
1.626.249.9663  
Christian@PrimoRoasting.com



## TECHNICAL DATA

RAVEN-XR15 INFORMATION		TECHNICAL DATA	
Green Coffee Capacity, Min - Max		15- 33 lbs. // 7 - 15 kg.	
Dimensions, Maximum (Including Cyclone)		90" L x 80" W x 78" H	
Shipping Weight		1650 lbs. // 748.42 kg.	
Roaster Weight		1200 lbs. // 544.3 kg.	
Cyclone Weight		300 lbs. // 136 kg.	
Full Batch Roast Time		9 - 14 Minutes	
Hourly Output		95 lbs. // 43.3 kg.	
Roast Air, Maximum		360 SCFM	
Cooling Tray, Air Maximum		1125 SCFM	
Roaster/Cyclone Exhaust Diameter		8" // 203.2 mm - 6" // 152.4 mm	
Temperature High Limit		500F. // 260C.	
<b>Gas Information</b>			
Gas Types		Liquid Propane (LP) or Natural Gas (NG)	
Maximum Consumption		300,000 BTU/hr.; 88 kWh	
Typical Consumption Per Roast		53,000 BTU/hr.; 15.5 kWh	
Inlet Gas Supply Connection		3/4" in. Male NPT	
<b>Electrical Information</b>			
Volts AC		220V // 14.5 AMPS.	
Frequencies		60Hz.	



# ROASTER DRAWINGS

NOT TO SCALE  
Dims - (Inches)

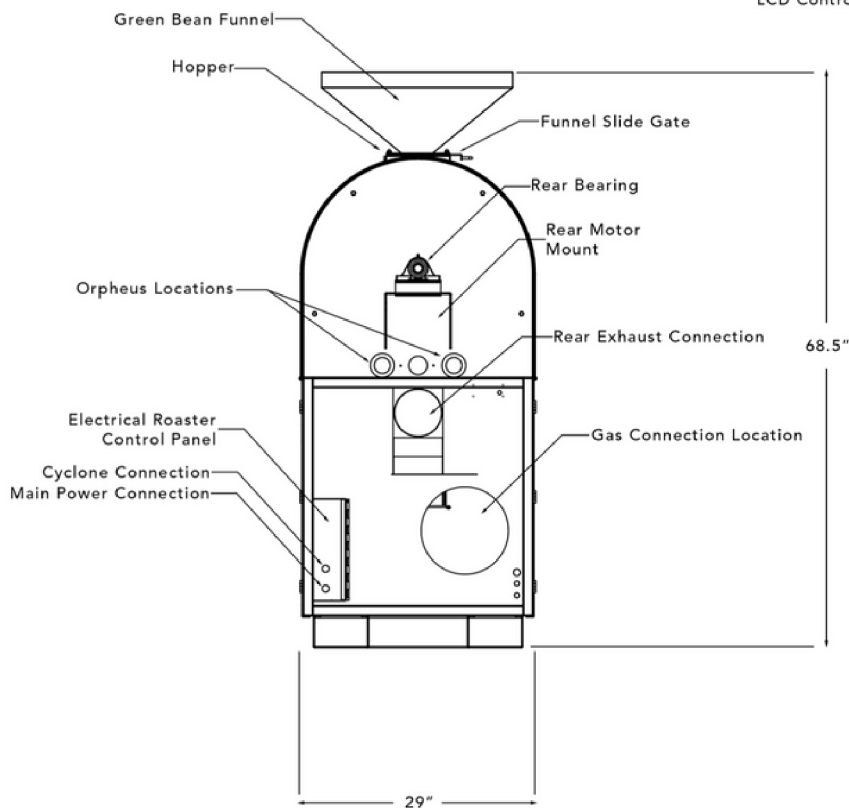
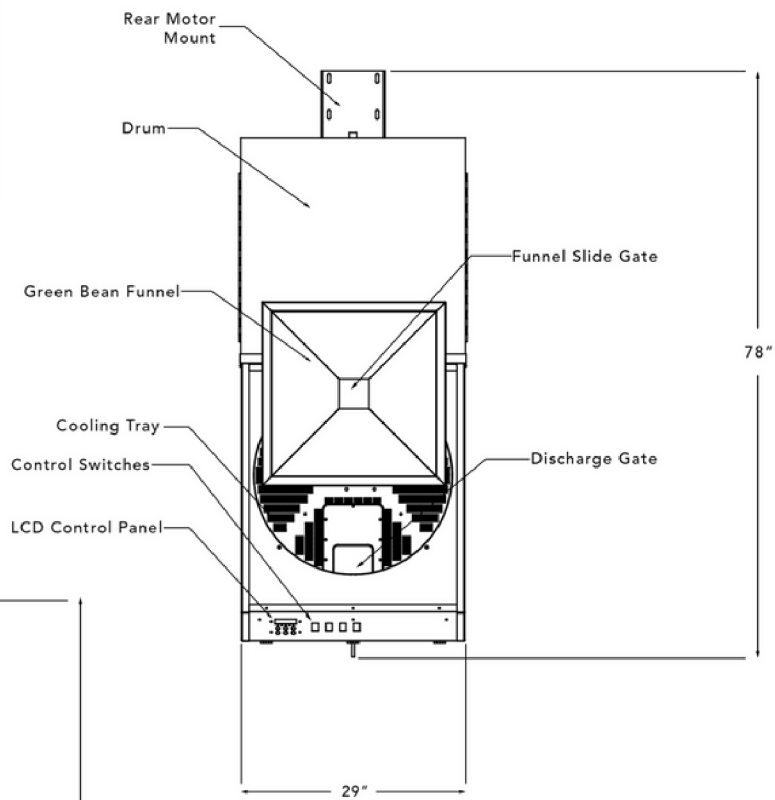
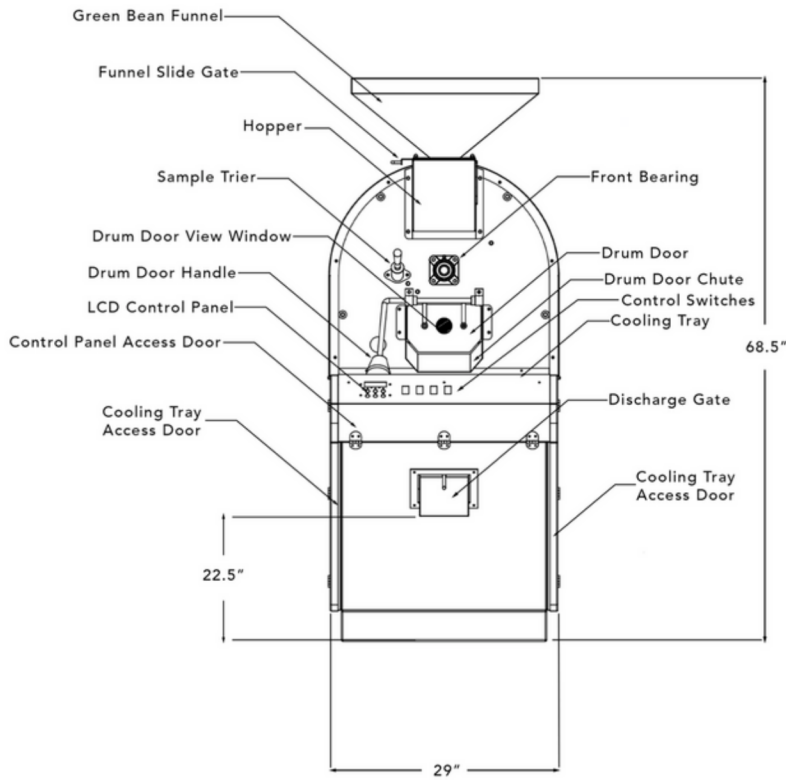



# ROASTER DRAWINGS

NOT TO SCALE  
Dims - (Inches)

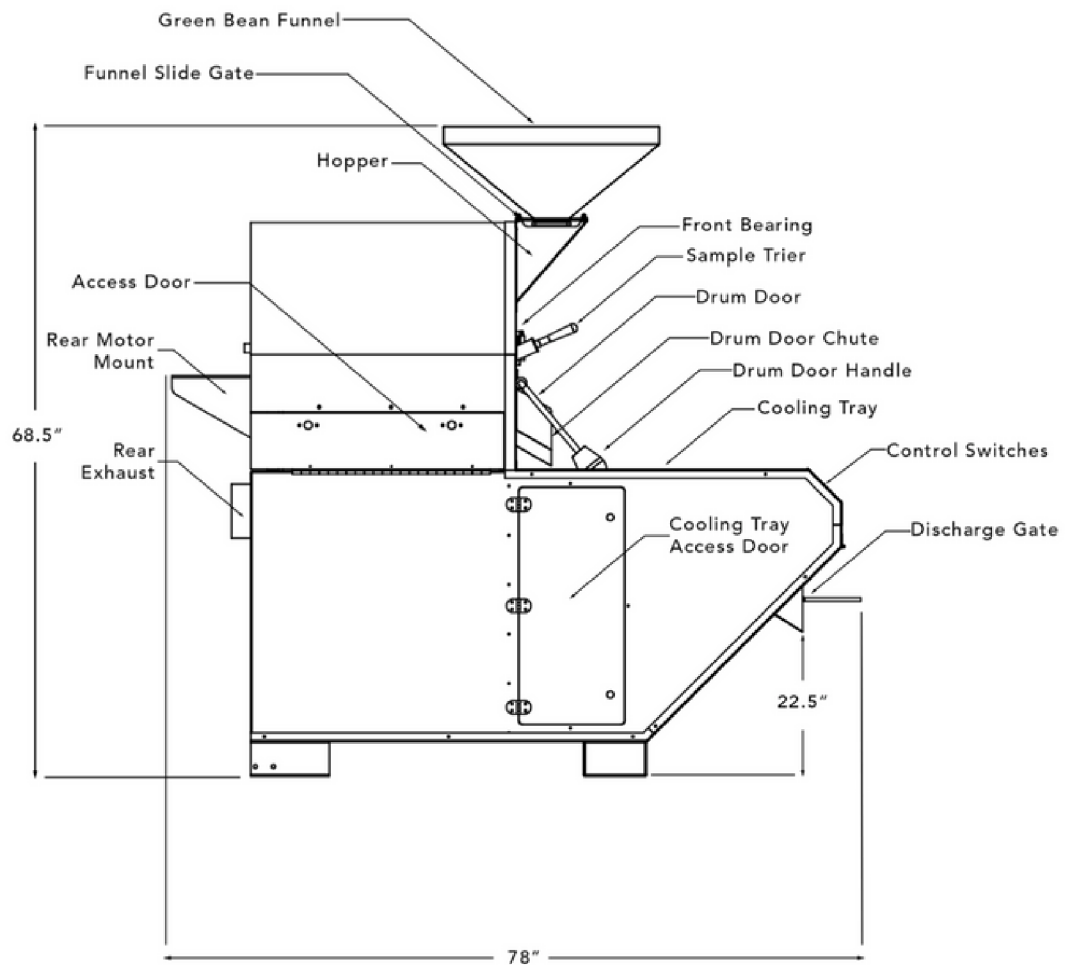
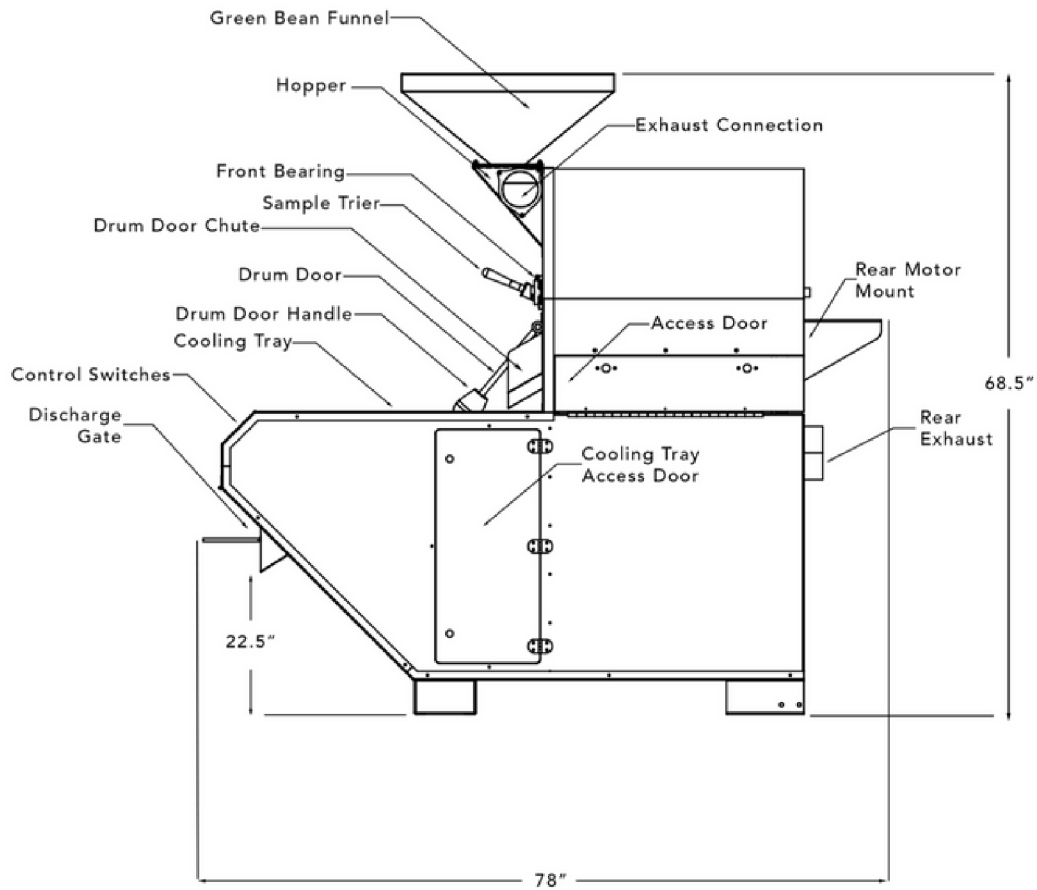



# ROASTER DRAWINGS

NOT TO SCALE  
Dims - (Inches)

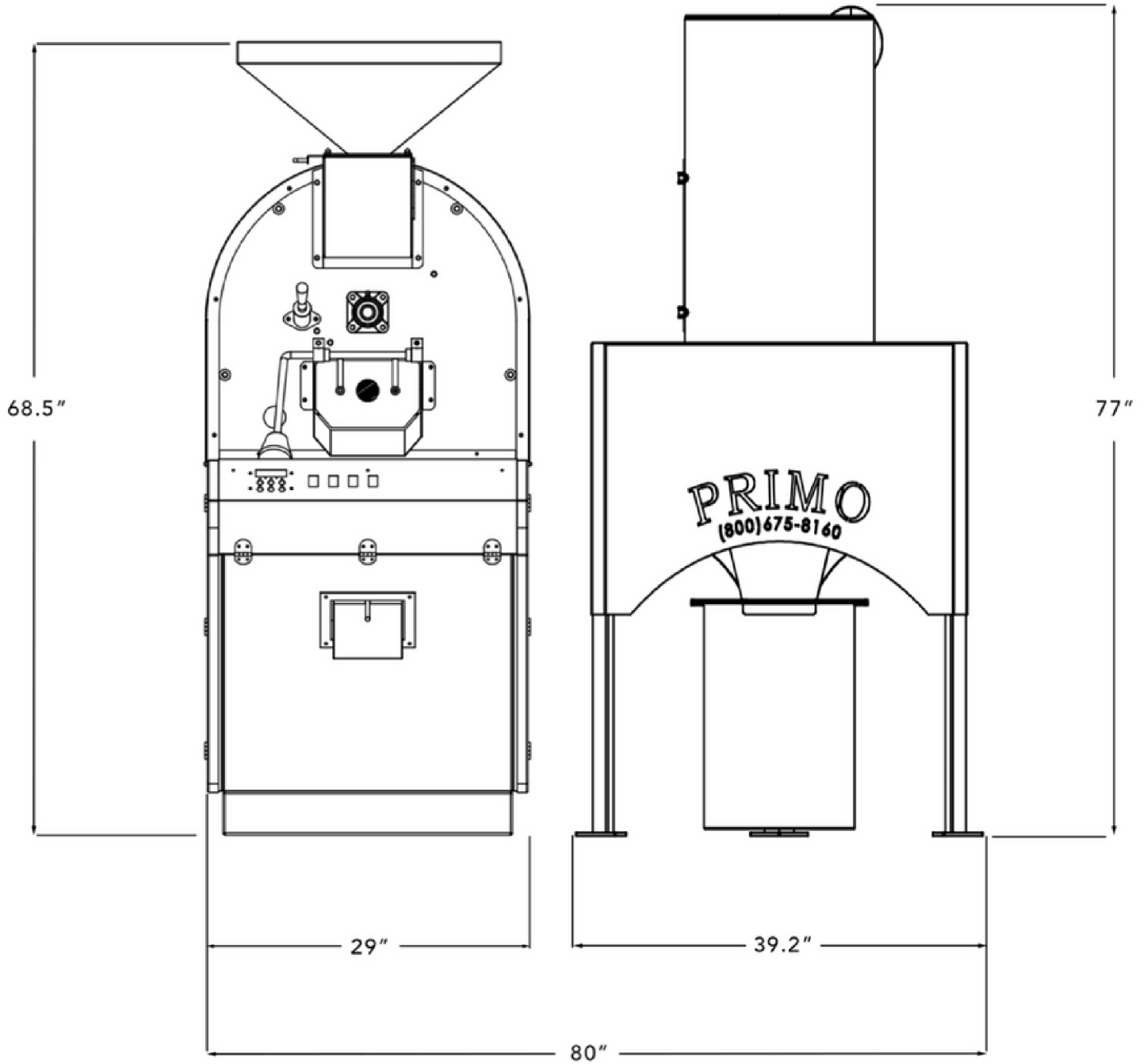



## SAFETY INFORMATION

---

Prior to installing & operating your roaster please read the entire manual. If you see this symbol in the manual, make sure to read what follows because it is a caution for actions that can cause harm or damage to your machine and/or the operator.

Death, injury, or property damage can be caused because of improper installation, adjustment, alteration, service, or maintenance. The entire installation guide must be read prior to installing, cleaning, operating, or servicing this roaster.



It is the owner's responsibility to ensure the installation, cleaning, and operation of the roaster are done safely/properly. Only a qualified professional should operate this roaster.

Keep any flammable items including but not limited to, gases, vapors, liquids, & solids, far away from the roaster at all times. The roaster needs to have a fire extinguisher nearby easily accessible in case of fire. Your local fire department will have information on which fire extinguishers should be used. Fires may be caused from not cleaning the roaster or exhaust system correctly and/or often enough.

The roaster needs 18 inches of space around it at all times. **Do not touch Hot surfaces.**

Once the installation of the roaster is completed, you will need to have it inspected to ensure it is compliant to local building codes. A local fire inspector must also inspect the machine. These things must be done prior to operating. The Primo Roasting Equipment warranty may be null/void if the inspections are not done. This would relieve Primo Roasting Equipment from any liability that has to do with the use of the machine & how the installation was done.

Instructions for what to do when the roaster operator finds a gas leak and/or smells gas need to be posted in a location easily accessible/readable. Your local gas company or company that supplies gas will have the instructions for you to get from them.



## RECEIVING & UN-CRATING

---

### Roaster:

The roaster comes in a crate.

Cut plastic walls off to expose roaster.

**\*Be careful not to drop/slide the tool you are using to cut into the crate, on the roaster\***

Once all walls are taken off, cut the steel cord strapped over the cooling tray to the pallet.

After the roaster is free standing on the pallet use forklift to move off of the pallet. Pick up roaster from the back of the machine to get off of the pallet

**\*Make sure to tilt the forklift arms up once roaster is in the air\***

**\*We recommend keeping the roaster as close to the ground as possible when moving\***

Set roaster in desired area **\*Spacing requirements further down\***

### Cyclone:

The cyclone comes bolted down on a pallet, wrapped in plastic.

Remove plastic wrap from cyclone & pallet Move pallet as close to desired position for the cyclone to make moving it easier.

**\*Use spacing requirements further down\***

**Remove bolts from cyclone legs.**

Pick up cyclone using forklift in-between the cyclone legs.

**\*Wrap and protect the forklift arms/cyclone arms to prevent abrasion on the cyclone when moving\***

Place cyclone on correct side of roaster using spacing requirements below.

### Spacing Requirements:

Be sure you have ample access to the green bean funnel, control panel, access doors, chaff bin, etc.

Space your roaster about 18" from back wall to ensure you have ample access for venting the machine.

The footprint of the roaster is 90" L x 80" W x 78" H. The cyclone must be placed 12" to the right of the roaster. The cyclone vent should be flush with the roaster vent to make adding the exhaust arm simple and easy. There must be easy access to the following areas: cyclone chaff bin, left and right side access doors, control panel, hopper, and gas line connection located on the back of the machine. Having easy access to these places will make cleaning and maintenance much easier.





## INSTALLATION

---

### Electrical:



**ATTENTION: Use a licensed electrical company when installing the electrical on your Primo roaster.**

Consult your licensed electrician to ensure proper installation of either the 110 V or 220 V, based off requested voltage. If using 220v a 3 prong 220v will not be included and must be wired to the 3 wires from the machine.

### Gas:



**ATTENTION: Use a licensed gas company when installing the gas line on your Primo roaster.**

Local codes, regulations, and/or laws must be followed when doing the gas installation for the machine.

\*Propane roasters must use propane only and are required to use a gas regulator.

\*Have a certified gas worker inspect and double check any gas connection work you do.\*

### Exhaust:

The exhaust air from the roasting process is hot and contains oils and residues which are flammable. In the event of a ducting/flue fire, the internal duct temperatures can exceed 1000° F (538°C), which could cause nearby combustible materials to ignite. Thus, Primo recommends, at a minimum, fire rated, positive pressure ducting that meets the applicable region/local standards, such as UL for USA, ULC for Canada, and CE for the European Union. An important consideration when designing an exhaust ducting system is the static pressure. The static pressure is the back-pressure or suction within the system. The exhaust ducting that connects to the roaster, cyclone, or afterburner, must be designed to operate with a static flue pressure between negative 0.15”WC (suction) and positive 0.25”WC (back-pressure) at the exhaust of the roaster (cyclone or Afterburner, as applicable) while in operation.

Ducting must be suitable for 500°F (260°C) continuous, 2,000°F (1,093°C) for 30, minutes, in the USA/Canada, and/or equivalent standards for other countries (such as CE standards for the European Union).

Installation must be done in accordance with appropriate NFPA standards in the USA or equivalent standards in other countries. The installation must also comply with the manufacturer’s installation specifications and allowable distance to combustible/ noncombustible materials.



## OPERATING MACHINE

---

The Raven-Xr15 has 4 buttons located on the control panel. The buttons in order from left to right: Main Power, Burner Ignition, Cooler, & Agitator. Every Raven-Xr15 is outfitted with a Delta PID. This PID shows your current drum temperature and allows you to set your desired temperature.

### Starting Roaster:

1. Make sure roaster is properly connected to the correct gas source.
2. Make sure roaster is properly plugged in to the correct outlet.
3. Make sure the chaff bin is empty and that the under cooler & side panels are clean of debris.

### How to turn roaster on: Roasting

1. Preheat roaster before first roast for 15-20 minutes or at 400 F.
2. Turn Roaster ON by pushing in the "POWER" button on the control panel of the roaster.
3. Next push in the "IGNITION" button to activate your burners.
4. You should hear the spark sensor activate to ignite the burners.
5. Set desired temperature on the PID, use keypad up and down arrows to set desired temperature.
6. Fill hopper with raw material.
7. Once filling stops pull funnel slide gate open to allow material to fall into the drum.
8. Close funnel slide gate.
9. Once the material reaches desired temperature turn on the agitator switch and the cooler switch.
10. When material is finished open drum door to allow all material to fall into the cooling tray.
11. Allow machine to reheat prior to next material drop.
12. Open discharge gate to allow first roast to be transported before the new roast reaches desired degrees.
13. Close discharge gate when all roasted material is out of cooling tray to prepare it for the batch currently roasting.
14. Repeat steps for multiple batches.

### Cooling:

Before dropping roasted material into the cooler tray turn on the agitator and cooler switches. Once your material has cooled to the desired temp you can open the discharge gate to drop material into storage bin. Be sure to close the discharge gate correctly before dropping the next batch of material into the cooler tray.

**Changing Drum Depth:**

1. Make sure machine is shut-off.
2. Loosen the two set screws on the front bearing with a 3/32" HEX Key.
3. Use a rubber mallet to push the drum axle back to desired distance \*Use rubber mallet as to not damage the machine. Do NOT hit any other part than the front flat section of the drum axle\*

**Grease Bearings:**

1. Add grease to front and rear bearing every 500 pounds of coffee.
2. Use greasing tool to add teflon grease to the pin on the side of the front bearing.
3. Wipe excess grease off with a rag.



**ATTENTION: Unplug machine prior to cleaning. Turn gas valve off prior to cleaning machine. Let machine cool down if hot prior to cleaning to avoid injury.**

**Cleaning:**

1. Empty chaff bin beneath cyclone, remove the bin by sliding it away from the cyclone. **\*Be sure the chaff bin is below cyclone prior to operating machine.\***
2. Open cooler tray access doors to vacuum out chaff that has fallen below the cooling tray. **\*Be sure to close both doors and lock latches before operating machine.\***
3. If the cooling tray screen has any blockages in it be sure to clean them out via a brush or tool to ensure maximum cooling is taking place.
4. Open side access doors on roaster by turning each of the knobs and lowering the panel. Remove the heat shield. Vacuum out the burner area to clear all chaff. **\*Be sure side panels are closed properly before your next roast.\***

**Every 10th Day Cleaning:**

1. Clean exterior of machine/cyclone using either compressed air or microfiber cloth.
2. Inspect front/rear drum bearings and lubricate as necessary.
3. Inspect all ducting on roaster/cyclone for accumulation. If necessary clean and remove the accumulation prior to cleaning.
4. Check blower motor fan and if necessary, clean.

**Annual Cleaning:**

1. Check all visible bolts/screws and tighten/replace if necessary.
2. Have a professional chimney cleaner sweep clean the exhaust ducting.